

# The Brose e-bike system

## Instructions for use



Instructions for use of Brose e-bike system

Reference number: BDA\_BeBS\_MY2017\_en\_v4.0 (valid for software of display unit .321)

# Table of contents

Figures.....	4
Quick start instructions.....	6
Drive unit .....	7
Display and control unit .....	10
Battery pack .....	14
Battery charger .....	18
Troubleshooting.....	21
Your notes .....	23

**1** Drive unit with design covers and fitted cranks

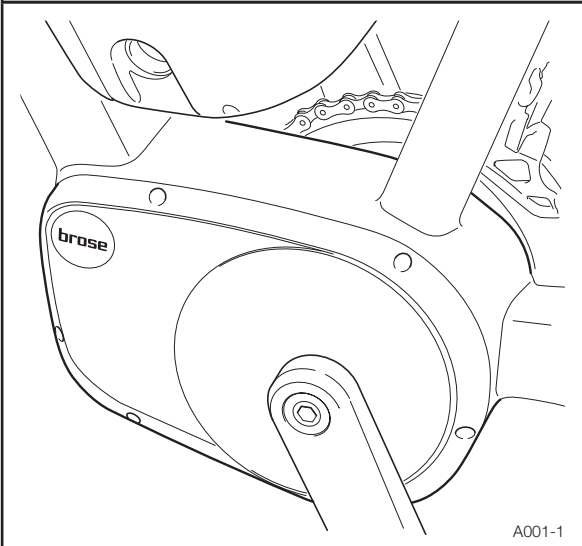

A001-1

**2** Attaching and removing the display unit

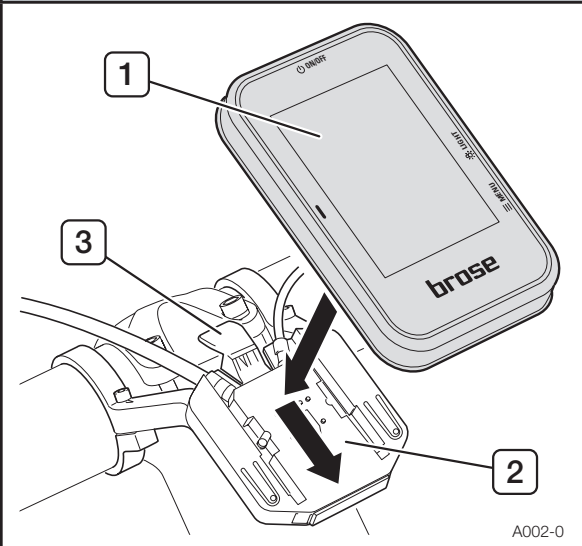

A002-0

**3** Securing the display unit

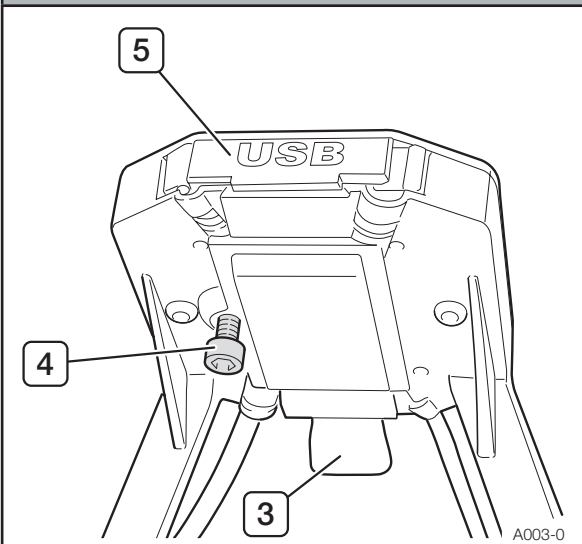

A003-0

**4** Buttons on the display unit

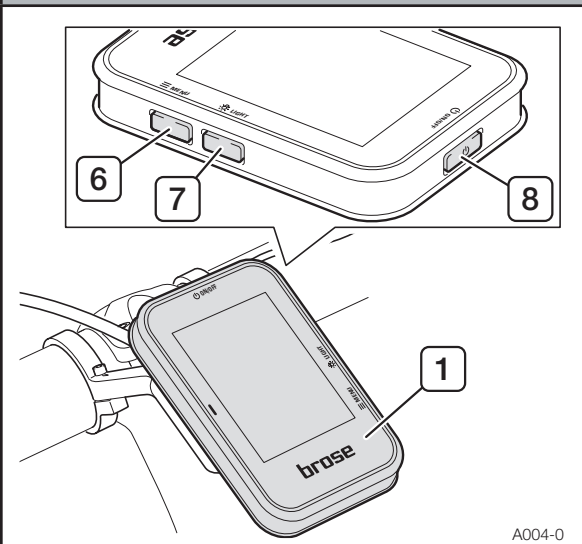

A004-0

**5** Functions of the display unit

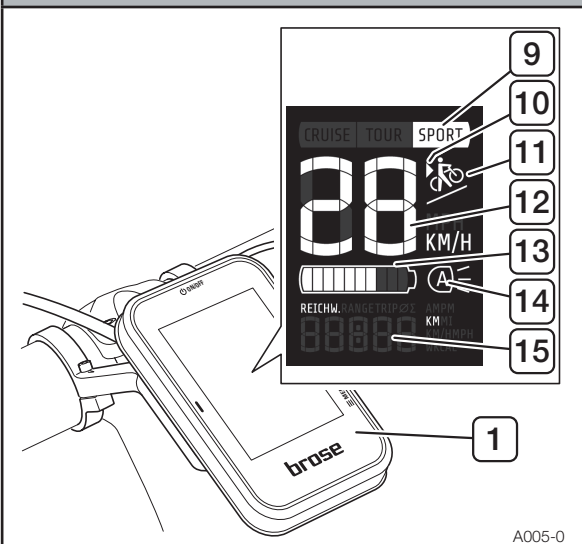

A005-0

**6** Buttons on the control unit

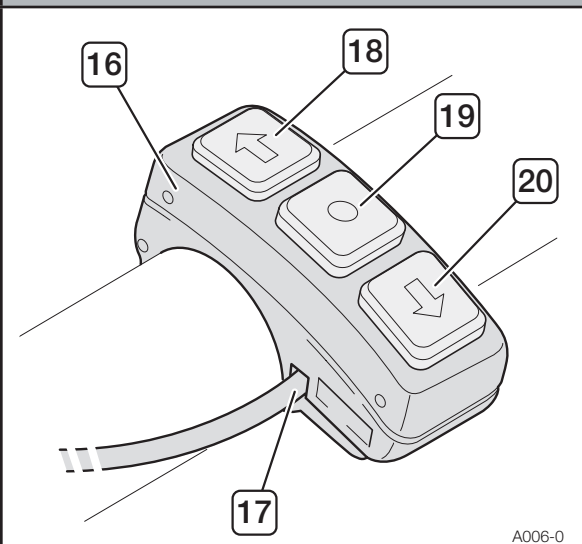

A006-0

### 7 USB interface

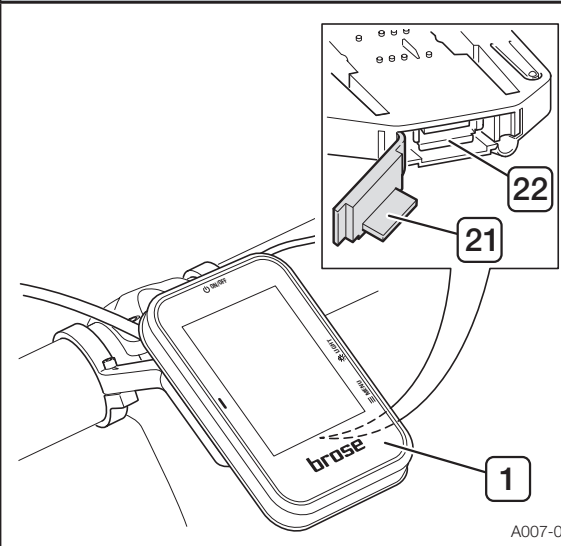

A007-0

### 8 Speed sensor and spoke magnet

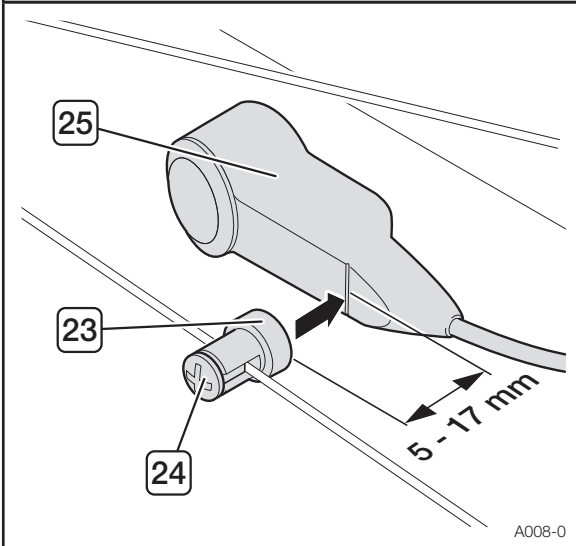

A008-0

### 9 Battery pack (example)

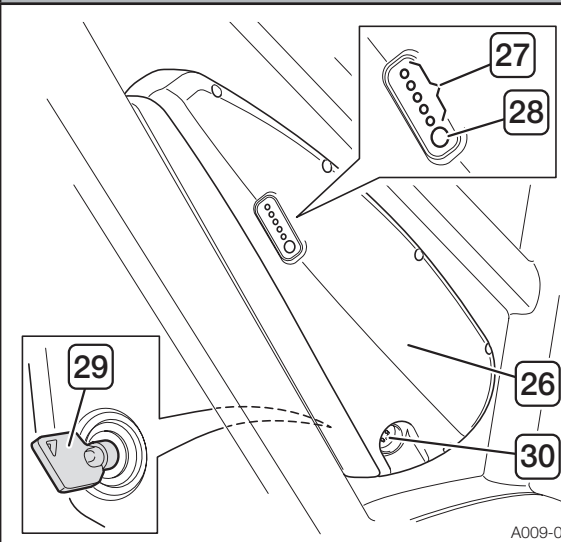

A009-0

### 10 Insert/removing the battery pack (example)

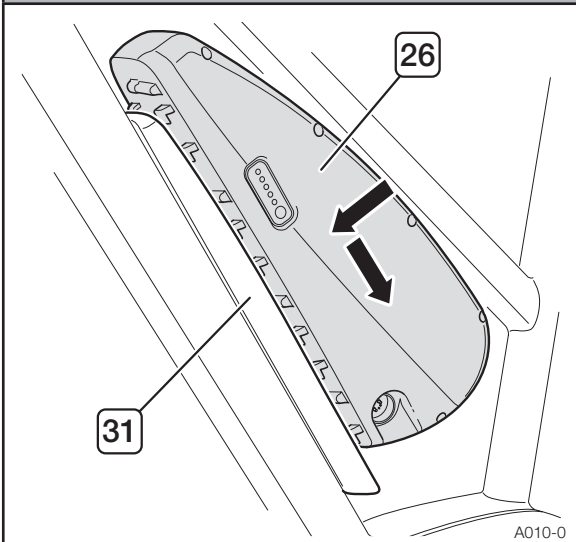

A010-0

### 11 Charging the battery pack (example)

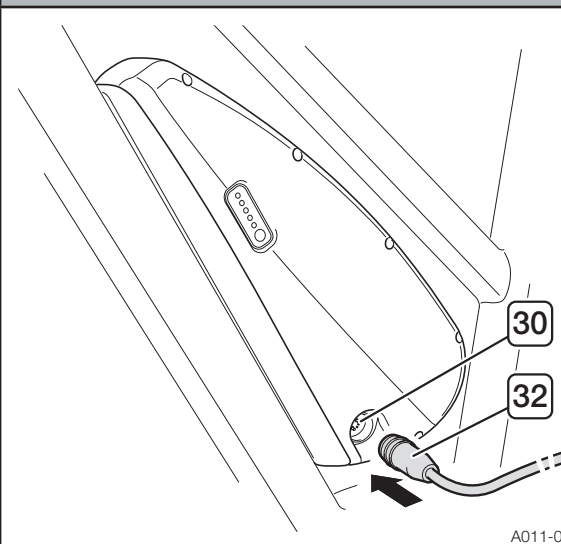

A011-0

### 12 Battery charger

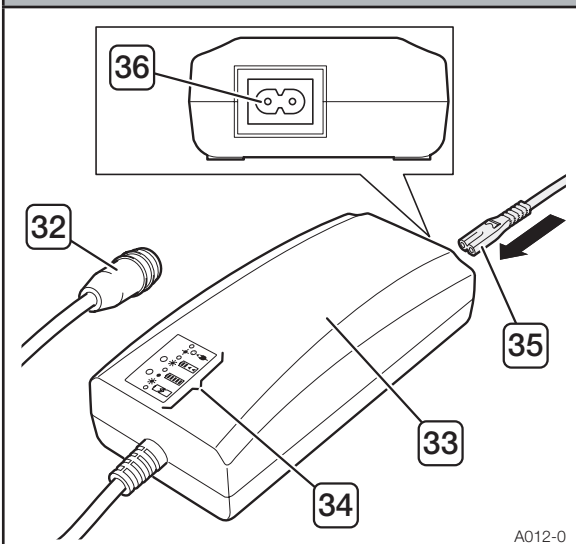

A012-0

# Quick start instructions

This section summarizes for you all the important information and instructions enabling you to use

your Brose e-bike system as quickly as possible.

**Step 1:** Insert battery pack (26) (example).

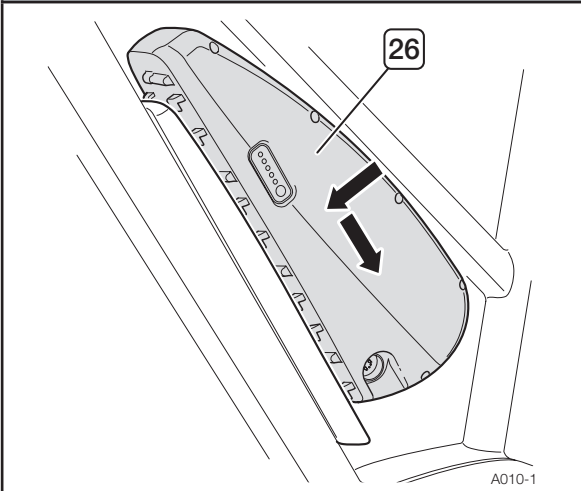

A010-1

**Step 2:** Fully charge battery pack (26) (example).

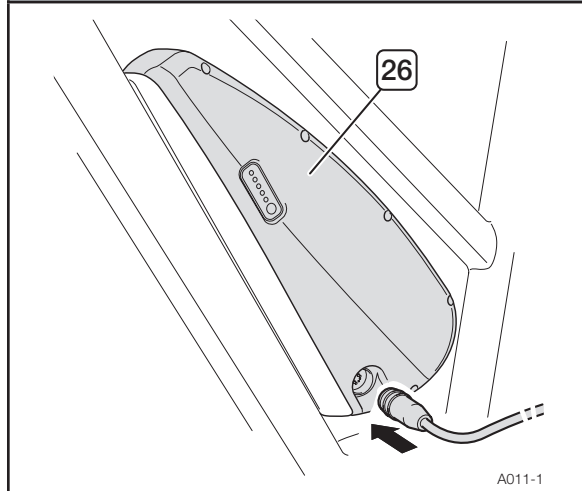

A011-1

**Step 3:** Lock battery pack key (29) (example).

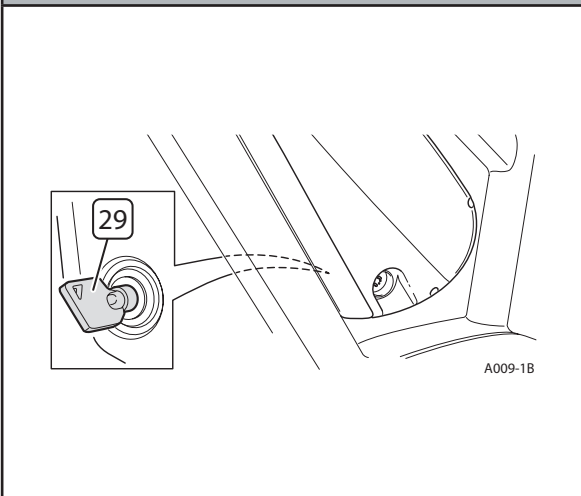

A009-1B

**Step 4:** Attach display unit (1).

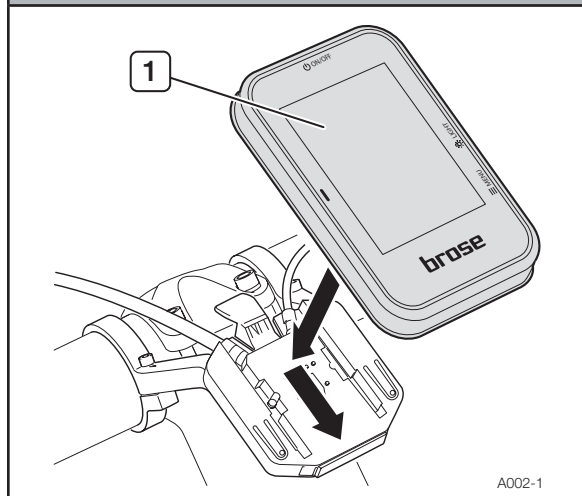

A002-1

**Step 5:** Activate Brose e-bike system using LED button (28) on battery pack (26) (example).

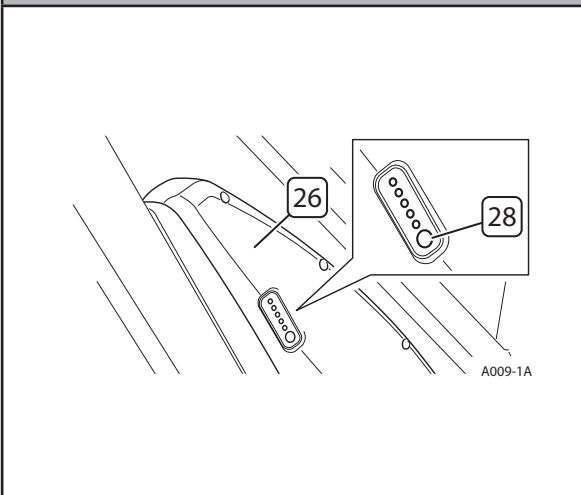

A009-1A

**Step 6:** Select the assist level using the control unit (16).

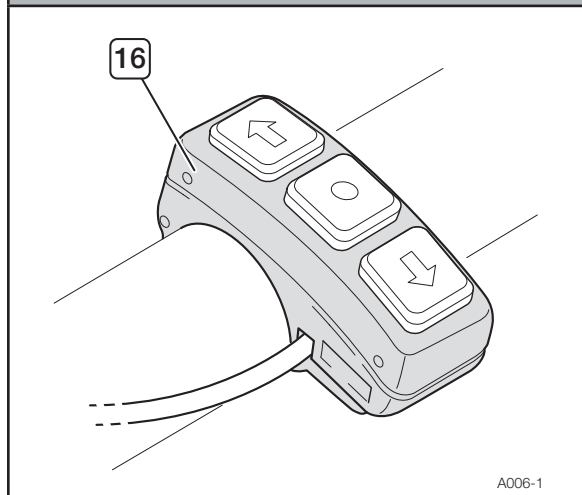

A006-1

# Drive unit

## Safety directions

- Please follow all safety directions and instructions found in both these Instructions for Use and in all other sets of instructions supplied with the e-bike.
  - Not following these safety directions and instructions can lead to electric shocks, fires and/or severe injuries.
- Keep these Instructions for Use safe for future reference.
- The term “battery pack” used in these Instructions for Use equally relates to downtube-mounted battery packs, rack-mounted battery packs and frame-integrated battery packs.
- Never open the drive unit. It is maintenance-free and may only be repaired by qualified experts using only original spare parts.
  - This ensures the safety of the drive unit. All warranty claims are invalidated if the drive unit has been opened without authorization.
- All components forming part of the e-bike system and parts fitted to the drive unit (e.g. chain ring, mounting of chain ring, pedals) may be replaced only by components approved by the manufacturer of the e-bike.
  - This protects the drive unit from damage (e.g. due to overloading).
- Remove the battery pack (26) from the e-bike before working on it (e.g. when fitting, servicing or working on the chain etc.), transporting it or placing it in storage.
  - There is a risk of injury if the e-bike system is activated by mistake.
- The push-assist may only be used when the e-bike is pushed.
  - There is a risk of injury if the wheels of the e-bike are not in contact with the ground when the push-assist is used.
- Do not make any alterations at all to your e-bike system. On no account attempt to improve the performance of your e-bike system.
  - If you do so, you will shorten the service life of its components and run the risk of damaging both the e-bike system and the e-bike itself. Furthermore, the warranty and any warranty claims will be invalidated if there has been any type of manipulation of the e-bike system. Incorrect handling of the e-bike system also endangers both your own health and that of other road users. By making your own alterations to the e-bike system, you run the risk of high personal liability costs or even criminal prosecution in the event of accidents due to manipulation.
- Please follow all national regulations relating to the licensing and use of e-bikes.

- Please read and follow the safety directions and instructions in the Instructions for Use of the battery pack (26) and in the Instructions for Use of your e-bike.
- Caution: There is a risk of burns if the motor casing is touched.

## Use for the intended purpose

The drive unit is intended solely for powering your e-bike and may not be used for any other purposes.

## Explanation of illustrations

All illustrations are diagrammatical and hence may differ in some details from your e-bike.

Fig.	Explanation
1	Drive unit with design covers and fitted cranks

## Operation

For information on operating the Brose e-bike system, please refer to the section on the display and control unit (see „Display and control unit“ on page 10).

*N.B.: The Brose e-bike system only operates when the display unit (1) has been attached.*

## Cycling instructions and tips

### When does the e-bike drive operate?

The Brose e-bike system permits electric motor assistance of the cyclist in a Pedal Electric Cycle (PEDELEC). This assistance depends on the force applied to the pedals by the cyclist. Assistance by the e-bike drive is therefore only provided when the cyclist is pedaling. This applies regardless of the assist level.

The e-bike drive switches off automatically at speeds of more than 25 km/h. If the speed drops below 25 km/h, the assist switches back on automatically.

An exception to this is the push-assist function, in which the e-bike can be pushed more comfortably at low speed without pedaling. When the push-assist is used, the pedals can also turn.

You can also use the e-bike at any time like a normal bike, without assistance, either by switching off the e-bike system or setting the assist level to “OFF” (see „Setting the assist level“ on page 12). The same applies when the battery pack (26) is flat.

## Familiarization

Take the time to get used to your Brose e-bike system before venturing into normal traffic conditions. Test the various assist levels until you feel confident in handling the system. Before setting off on long trips, gain experience of how different parameters and ambient conditions affect the range of your e-bike.

## Motor setups

The Brose e-bike system supports various motor setups. The following tells you more about the characteristics of the different settings. Detailed information about motor set-up for your e-bike is available from the bicycle manufacturer and your bicycle dealer.

## Effects on range

The range is affected by many factors, such as:

- Assist level
  - The higher the selected assist level in otherwise identical conditions, the shorter the range.
- Gear changing style
- Type of tire
- Tire pressure
- Age, standard of care and charge level of battery pack (26)
- Route type (slopes) and conditions (road surface)
- Weather conditions (e.g. head wind, ambient temperature etc.)
- Weight of e-bike
- Payload.

## Careful handling of the Brose e-bike system

Take care with the temperatures at which the e-bike components are operated and stored. Protect the drive unit, the display unit (1) and the battery pack (26) from extreme temperatures (e.g. due to intensive sunlight without ventilation to compensate). The components (particularly the battery pack (26)) might be damaged by extreme temperatures.

## Maintenance & cleaning

Keep all the components of your e-bike clean, in particular the contacts of the battery pack (26) and its mounting (31). Clean them carefully with a soft and dry cloth.

All components including the drive unit must not be dipped in water or cleaned using a high-pressure cleaner.

For servicing or repairs to the e-bike, please contact an authorized bicycle dealer.

## Inspection

**For the drive unit, an inspection by a service center certified by Brose is mandatory after a distance covered of 15,000 km.**

**Information on the service center responsible for you is available from your cycle dealer.**

## Transport

When transporting a complete e-bike, please follow the instructions for transporting battery packs (see „Transport“ on page 17).

## Disposal

The drive unit, display and control unit, battery pack (26), speed sensor (25), accessories and packaging should be recycled in environment-friendly processes. Do not dispose of e-bikes and their components as normal waste!

### For EU countries only:





In line with the European Union directive 2012/19/EU, electrical appliances which are no longer serviceable must be collected separately and recycled in environment-friendly processes, and in line with directive 2006/66/EC the same applies for defective or used-up batteries.

Please hand in battery packs (26) and display units (1) which are no longer serviceable to an authorized bicycle dealer.



## Specifications

<b>Brose drive unit 25km/h (20mph)</b>	
Brose material number	C16162 / C91143
Dimensions	213 x 150 x 128 mm
Weight	3.400 g
Nominal voltage	36 V 
Ingress protection rating	IP56
Torque max.	90 Nm
Rated continuous power	250 W
Pushing aid (Scoop)	up to 6km/h (4mph)

<b>Brose drive unit 45km/h (28mph)</b>	
Brose material number	C79232 / C97292
Dimensions	213 x 150 x 128 mm
Weight	3.400 g
Nominal voltage	36 V 
Ingress protection rating	IP56
Torque max.	90 Nm
Rated continuous power	250 W
Starting aid	up to 20km/h (13mph)
Pushing aid (Scoop)	Pushing aid (Scoop)

# Display and control unit

## Safety directions

- Please follow all safety directions and instructions found in both these Instructions for Use and in all other sets of instructions supplied with the e-bike.
  - Not following these safety directions and instructions can lead to electric shocks, fires and/or severe injuries.
- Keep these Instructions for Use safe for future reference.
- The term "battery pack" used in these Instructions for Use equally relates to downtube-mounted battery packs, rack-mounted battery packs and frame-integrated battery packs.
- Remove the battery pack (26) from the e-bike before working on it (e.g. when fitting, servicing or working on the chain etc.), transporting it or placing it in storage.
  - There is a risk of injury if the e-bike system is activated by mistake.
- The push-assist may only be used when the e-bike is pushed.
  - There is a risk of injury if the wheels of the e-bike are not in contact with the ground when the push-assist is used.

## Use for the intended purpose

The display and control unit of the Brose e-bike system is intended solely for use in the latter. It is used to display information relevant for cycling and status and to control the drive unit.

## Key to illustrations

The numbering of the components described relates to the illustrations on the picture pages at the beginning of these instructions (see page 4-5). All illustrations are diagrammatical and hence may differ in some details from your e-bike.

Item	Fig.	Explanation
1	2/4/5/7	Display unit
2	2	Mounting of display unit
3	2/3	Unlocking button of mounting
4	3	Fastening bolt
5	3	Position of USB interface
6	4	Menu button
7	4	Light button
8	4	On/Off button
9	5	Display of assist level
10	5	Display of push-assist
11	5	Display of cycling speed
12	5	Display of battery pack charge level

Item	Fig.	Explanation
13	5	Display of light mode
14	5	Display of multifunctional panel
15	6	Control unit
16	6	Cable routing of control unit
17	6	"Raise assist level" button
18	6	Multifunctional panel button
19	6	"Lower assist level" button
20	7	Cover cap of USB interface
21	7	USB interface
22	8	Spoke magnet
23	8	Fastening bolt of spoke magnet
24	8	Speed sensor

## Assembly

### [Fig. 2] Attaching the display unit

- Attach the display unit (1) with the guide groove on the rear face into the guide opening of the mounting (2).
- Slide the display unit (1) all the way down until you hear it snap into place.

### [Fig. 3] Removal preventer

The mounting (2) has an optional removal preventer.

- Where applicable, screw the fastening bolt (4) lightly from underneath into the mounting (2) once the display unit (1) is in place.

### Removing the display unit

- Deactivate the display unit (1) before removing it from the mounting (2).
- Undo the fastening bolt (4), where applicable.
- Keep the unlocking button (3) pressed down and push the display unit (1) upwards inside its guide opening until it can be removed from the mounting (2).

*N.B.: An integrated memory ensures that your data (e.g. clock time, kilometers per day, cycling time etc.) are saved when the display unit (1) is removed.*

## Putting into service

Putting the display and control unit into service does not require any further steps after assembly. The display and control unit is ready to operate as soon as it has been correctly attached into the mounting (2).

*N.B.: Full functioning is only possible when the speed sensor (25) and the cables have been correctly fitted and the battery pack (26) sufficiently charged.*

## Operation

Once the display unit (1) is in place inside the mounting (2), a battery pack (26) with sufficient charge has been inserted into the e-bike and the e-bike system has been switched on, the display unit (1) is supplied with power by the battery pack (26).

*N.B.: The display unit (1) does not have its own battery and so cannot be used or operated outside of its mounting (2).*

*N.B.: As soon as the battery pack (26) is in "Active Mode", the display unit (1) always remains switched on during cycling, even if the motor assist has been deactivated.*

### Switching on the Brose e-bike system

- Press the LED button (28) on the battery pack (26).
  - The display unit (1) activates automatically.
  - The e-bike is now ready to use.

### Switching off the Brose e-bike system

#### Standby mode

If the e-bike is not moving, the display unit (1) and the drive unit switch to a standby mode. This can however also be activated manually.

If you want to park your e-bike only for a short period, this is how you switch to the standby mode:

- Press the On/Off button (8) briefly (< 2 seconds).
  - This switches off the display unit (1) and the drive unit.
  - The battery pack (26) remains in the "Active Mode" for two hours (see „Operating modes of battery pack“ on page 16).
- As soon as you move your e-bike again, the display and the drive unit are re-activated and the Brose e-bike system is ready to use again.
- After 2 hours in the "Active Mode", the battery pack (26) goes into the "Deep Sleep Mode" (see „Operating modes of battery pack“ on page 16).

#### Complete switch-off

There are two ways to switch off the Brose e-bike system completely:

- Press the On/Off button (8) for a long time (< 2 seconds).

OR

- Press the LED button (28) on the battery pack (26) for a long time (< 3 seconds).

- Now this display unit (1), the drive unit and the battery pack (26) are completely switched off.

*N.B.: For reactivation after complete switch-off, the system must be restarted using the LED button (28) on the battery pack (26) (see „Switching battery pack on and off“ on page 16).*

### [Fig. 5] Displays and settings

The display unit (1) shows various useful information:

- selected assist level (9)
- activity of push-assist (11)
- current cycling speed (12)
- current charge level of battery pack (13) in 10-percent increments
- light mode (14)
- multifunctional panel (15)

#### Background lighting

The background lighting is activated for 2 seconds whenever a button is pressed. The brightness here is 100 %.

At night, the background lighting is active all the time. The brightness is much lower here so that the cyclist is not dazzled. Brightness is regulated depending on the ambient light.

#### Battery charge and remaining range

The charge level (13) of the battery pack is shown in the display of the display unit (1) with 10 segments. One segment here corresponds to about 10 % of the battery capacity (see „Charge level display“ on page 16).

If the charge level is less than 20 %, the charge level display will start to flash. When the charge level is less than 6 % the charge level indicator will fade out. In this state the motor assist switches off, in order to ensure that the lights can be used for another two hours if need be.

#### Display change in multifunctional panel (15)

- Press the menu button (6) on the display unit or the multifunctional panel button (19) on the control unit to switch between the functions of the multifunctional panel (15).

The multifunctional panel (15) presents the following information:

- Range time
- Trip distance
- Trip average speed
- Trip time
- Pedal resistance of driver
- Total kilometers
- Total time
- Clock time

*Note: Some functions can be deactivated, depending on the bicycle model. Detailed information is available from the bicycle manufacturer and from your bicycle dealer.*

#### Changing over the measurement units

- Switch off the display unit (1) using the On/Off button (8) (press it briefly for < 2 s).
- Press the On/Off button (8) and the menu button (6) simultaneously for > 3 s until the software version of the display unit (1) appears in the multifunctional panel (15).
  - All displayed units are changed over between “km” and “mi” and “km/h” and “mph” respectively.

#### Setting the clock time

- In the multifunctional panel (15), change to the display of the clock time by pressing the menu button (6).
- Press the menu button (6) for > 2 s.
  - The hour display flashes.
- Set the hour display using the buttons “Raise assist level” (18) and “Lower assist level” (20).
- Confirm your entry using the menu button (6) or the multifunctional panel button (19).
  - The minute display flashes.
- Set the minute display using the buttons “Raise assist level” (18) and “Lower assist level” (20).
- Confirm your entry and leave the menu using the menu button (6) or the multifunctional panel button (19).

#### Reset trip functions

To reset the displayed values of the trip functions in the multifunctional panel (15), proceed as follows:

- Press the menu button (6) on the display unit or the multifunctional panel button (19) on the control unit to select any trip function.
- Press the menu button (6) or the multifunctional panel button (19) for more than 2 seconds.
  - All displayed values for the trip functions are reset to 0.

- Press the On/Off button (8) and hold it (longer than 2 seconds) to delete the memory for the trip function.

#### Reset total time

To reset the displayed value of the “Total time” function in the multifunctional panel (15), proceed as follows:

- Select the “Total time” function by pressing the menu button (6).
- Press the menu button (6) for > 2 seconds.
  - The displayed value of the “Total time” function is reset to 0.
- Press the On/Off button (8) and hold it (longer than 2 seconds) to delete the memory for the „Total time“ function.

#### Displaying the software version number of the display unit

To display the software version number of the display unit (1) in the multifunctional panel (15) proceed as follows:

- Briefly press (less than 2 seconds) the On/Off button (8).
  - Display unit (1) is switched off.
- Press and hold (for longer than 5 seconds) the On/Off button (8).
  - The software version number of the display unit (1) is displayed in the multifunctional panel (15).

#### Basic functions

Your Brose e-bike system has three assist levels (9). Their characteristics are set out in the following table:

Description	
<b>Off</b>	No motor assist. At the same time, cycling without any resistance.
<b>Cruise</b>	Cyclist dominates, with perceptible assistance by the motor.
<b>Tour</b>	Motor enhances the strength of the cyclist over-proportionally (and yet sustainably).
<b>Sport</b>	Full delivery of the motor force with little effort by the cyclist.

#### Setting the assist level

- Press the button “Raise assist level” (18) on the control unit (16) to increase the assist level from OFF to SPORT.
- Press the button “Lower assist level” (20) on the control unit (16) to reduce the assist level from SPORT to OFF.

*N.B.: If the control unit (16) on your e-bike has been installed reversed by 180°, then the button functions of items 18 and 20 are reversed. It is always the button*

with the arrow pointing in the cycling direction that raises the assist level.

#### Activating/deactivating the push-assist

The push-assist (11) is used for assistance when pushing the e-bike. It is activated as follows:

- Switch the assist level to “OFF” to activate the push-assist (11).
  - The arrow (10) is activated in the display of the display unit (1) and signals that the push-assist (11) is ready to operate.
- Press the button “Lower assist level” (20) down for > 1 second to activate the push-assist (11).
  - This activates the symbol for the push-assist (11) in the display unit (1).
  - The e-bike accelerates without pedal assist to a manufacturer-specified speed of between 3 and 6 km/h
- Release the button “Lower assist level” (20) to deactivate the push-assist (11).

#### Expanded functions

##### Light mode (14)

You can switch the lighting on or off manually, or select the automatic mode that automatically activates and deactivates the lighting depending on the ambient brightness.

- Press the light button (7) to switch the light on or off.
- Press the light button (7) for > 2 seconds to switch the automatic mode on or off.
  - An “A” inside the light symbol (14) comes on or goes out.

##### [Fig. 7] Power supply via USB interface

External devices can be supplied with power and charged using the Type A USB interface (22) integrated into the mounting (2).

- Attach the display unit (1) into the mounting (2).
- Open the cover cap (21) of the USB interface (22).
- Use a suitable USB cable to make the connection between the USB interface (22) and the required end device.
  - If the connection is successful, the display “CHArG” briefly appears in the display unit (1).

#### Maintenance & cleaning

Keep all the components of your e-bike clean, in particular the contacts of the battery pack (26) and its mounting (31). Clean them carefully with a soft and dry cloth.

All components including the drive unit must not be dipped in water or cleaned using a high-pressure cleaner.

For servicing or repairs to the e-bike, please contact an authorized bicycle dealer.

#### Disposal

The drive unit, display and control unit, battery pack (26), speed sensor (25), accessories and packaging should be recycled in environment-friendly processes. Do not dispose of e-bikes and their components as normal waste!

##### For EU countries only:



In line with the European Union directive 2012/19/EU, electrical appliances which are no longer serviceable must be collected separately and recycled in environment-friendly processes, and in line with directive 2006/66/EC the same applies for defective or used-up batteries.

Please hand in battery packs (26) and display units (1) which are no longer serviceable to an authorized bicycle dealer.

#### Specifications

Display and control unit	
Brose material no. Display unit	C54764
Brose material no. Control unit	C54760
Dimensions of display unit	44,0 x 62,5 x 8,0 mm
Dimensions of display area	38,0 x 50,0 mm
Dimensions of control unit	18,0 x 46,0 x 19,75 mm
Weight of display unit	67 g
Protection class	IP65
Working temperature range	-10 to 60°C
Storage temperature range	-20 to 85°C
USB charge voltage	5 V $\equiv$
USB charge current max.	500 mA

Lights	
Rated voltage	6 V $\equiv$
Nominal current max.*	500 mA
Rated output*	
- Front light	2,6 W
- Rear light	0,6 W

\* The rated power of the lights can differ depending on the battery pack model used. Detailed information can be obtained from the bicycle manufacturer and your bicycle dealer.

# Battery pack

## Safety guidelines

### **WARNING**

**There is a risk of danger, if the safety instructions are not observed**

*Non-observance of safety information and instructions can lead to an electrical shock, fire and/or serious injuries.*

*Injuries or damage is also possible as a result of dangerous reactions of chemical substances that leak from the rechargeable battery resulting from non-observance of the safety instructions.*

- Please observe all safety information and instructions both in these and in all other instructions included with the e-bike.
- **CAUTION:** Risk of injury if the e-bike system is activated unintentionally. Before working on the e-bike (e.g. assembly, maintenance, working on the chain etc.), or transporting or storing it, please remove the battery pack from the e-bike.
- **CAUTION:** Risk of injury when using the pushing aid without the wheels touching the floor. Only use the pushing aid when pushing the e-bike.
- Risk of short circuits! Do not open, dismantle or chop up the battery pack. Opening the battery pack will invalidate the warranty.
- Risk of explosion! Protect the battery pack from heat (e.g. also from permanent exposure to sunlight), fire and submersion into water.
- Risk of burns and fire caused by short circuits! Keep small metal objects (e.g. paper clips, nails, screws, keys etc.) away from the battery pack. These could bridge the contacts. All warranty claims toward Brose will become invalid in case of short circuit damage resulting from this.
- Risk of skin irritation or burns from leaking fluids: if used incorrectly, fluid can leak from the battery pack. Avoid contact with this. In case of accidental contact, rinse the affected areas with water. If the fluid comes into contact with mucous membranes (e.g. eyes), please seek medical attention immediately.
- Do not expose the battery pack to mechanical impacts. There is a risk of damage to the battery pack.
- The risk of short circuits and fire or an electrical shock is higher, if a damaged battery pack is used. Never continue to use a faulty or damaged battery pack.
- Vapours may irritate the respiratory organs. Vapours may be created if the battery pack is damaged or

*used incorrectly. Let in fresh air and seek medical advice if symptoms persist.*

- Risk of fire due to use of other chargers. Only charge the battery pack with the charger supplied with the e-bike system.
- Only use the battery pack in conjunction with e-bikes with the original Brose e-bike system. This is the only way to protect the battery pack from dangerous overloading.
- Risk of injury or risk if other battery packs are used: only use battery packs approved by the bike manufacturer for your e-bike. The warranty and liability will become invalid if other battery packs are used.
- Keep the battery pack away from children.
- Always keep the battery pack dry and clean.
- Always keep the contacts of the battery pack clean. If they are soiled, clean them with a dry cloth.
- Avoid unnecessary charging. Do not charge the battery pack for a longer period, if you are not going to use it.
- Please keep these instructions for future reference.
- Never leave the battery pack and battery charger unattended during charging.

## Intended use

The battery pack is designed and intended for use in a Brose e-bike system.

## Explanation of the figures

All illustrations are outlines only and serve as examples. The details may vary from your own e-bike because the Brose e-bike system can be combined with a number of different battery pack variants. You can obtain detailed information about the battery pack used in your e-bike from your cycle manufacturer and your bicycle dealer.

## Assembly

### Insertion and removal of the battery pack



The Brose e-bike system can be combined with a number of different battery pack variants. The assembly and removal of the battery pack depends on the battery pack model used. You can obtain detailed information about this from your cycle manufacturer and your bicycle dealer.

*N.B.:* Always switch the battery pack off before placing it into or removing it from the bracket.

### Locking and unlocking the battery pack latch

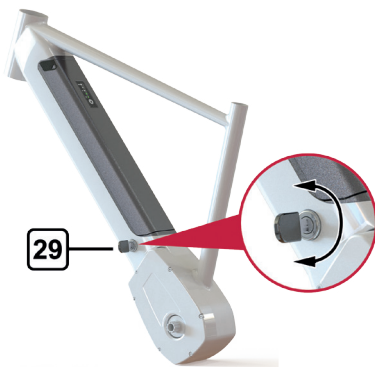

The various assembly variants of the battery pack require various battery pack latch designs. You can obtain detailed information about locking and unlocking the battery pack from your cycle manufacturer and your bicycle dealer.

## Commissioning

### Check the battery pack before using it for the first time

The battery pack is partially charged when delivered. Therefore, test the battery pack before you charge it for the first time or use it with your e-bike.

- Activate the battery pack by pressing the LED button.
  - The charging status display should now switch from 'empty' to 'full' and then the current display status is shown for approx. 4 seconds.
  - If no LED on the charging status display shines or if the battery pack cannot be activated, it may be possible that the cell voltage is too low and the battery pack needs to be charged.
  - If at least one but not all LEDs of the charging status display shine, the battery pack should be fully charged before it is used for the first time.

### Charging the battery pack

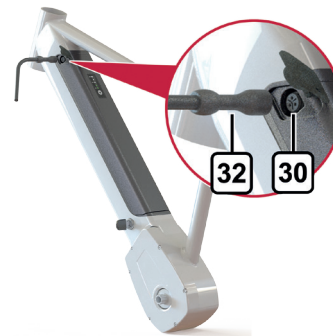

Only use the charger supplied with your e-bike. Only this charger matches your battery pack.

*N.B.:* The battery pack is partially charged when delivered (approx. 30-50 %). To guarantee the full performance of the battery pack, charge it completely with the battery charger before it is used for the first time (see also, "Battery charger" on page 18).

The battery pack can be charged separately or on the e-bike without reducing the service life.

- Connect the battery charger to the mains supply.
  - The LED status display of the battery charger should now be active (see "Battery charger" on page 18).

### Battery pack not on the e-bike:

- Connect the battery charger connector to the charging socket of the battery pack.
  - Charging begins.

*N.B.: Some battery packs may have two charging connections. It does not matter which of the two connections is used for the charging process.*

**Battery pack on the e-bike:**

- Connect the battery charger connector to the free charging socket of the battery pack.  
→ Charging begins.

*N.B.: Interrupting the charging process does not damage the battery pack.*

*N.B.: If the battery pack cannot be charged, the cell voltage has undercut the critical value of 2V per cell and the battery pack is faulty.*

*N.B.: Do not charge a damaged battery pack and do not use it. Please contact an authorised dealer.*

*N.B.: The battery pack reaches its maximum service life, if it is charged in ambient temperatures between 10 and 30°C.*

**Charging status display**

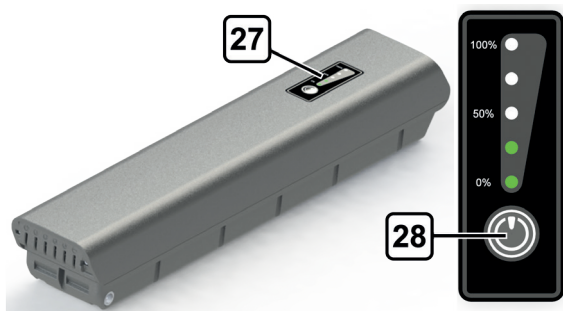

**When cycling and when the battery pack is disconnected**

The five LEDs on the charging status display (27) show the charging status of the battery pack after pressing the LED button (28). Each LED equates to about 20% capacity. All five LEDs will light up when the battery pack is fully charged. The charging status of the activated battery pack is also shown on the display of the display unit (see “Display and control unit” on page 10). If the capacity of the battery pack lies below 10 %, the first LED on the charging status display flashes.

**During charging**

The battery pack can be charged with and without the display unit. Without a display unit, the battery charger can only be monitored on the charging status display. The display unit can be removed during the charging process or can even be positioned after the start of the charging process. The charging status is shown with the charging status display on the battery pack and via the bar on the display. During the charging process, the LEDs of the charging status display on the battery pack shine. Each LED that shines permanently corresponds

to about 20% of the capacity. The flashing LED shows the charging of the next 20 %.

During the charging process, the charging status display is presented as follows:

LEDs	Charging status
*○○○○	0-19 %
●*○○○	20-39 %
●●*○○	40-59 %
●●●*○	60-79 %
●●●●*	80-99 %
●●●●●	100 %

**Operation**

**Switch battery pack on and off**

**Switching on**

One way of switching on the e-bike system is to switch on the battery pack.

- Press the LED button on the battery pack (see 28).  
→ The LEDs of the charging status display shine briefly and then show the current display status for approx. 4 seconds.

*N.B.: If the capacity of the battery pack lies below 10 %, only the first LED on the charging status display flashes (27).*

**Switching off**

- To switch off the battery pack, press the LED button for > 3 seconds (28).  
→ The LEDs of the charging status display (27) go off.  
→ The e-bike system is also switched off at the same time.

**Operating modes of the battery pack**

**Active Mode**

Once it is switched on, the battery pack is in **Active Mode**. If no further action is taken (operation or moving the e-bike), it remains in **Active Mode** for two hours.

The **Active Mode** is activated by pressing the LED button (28), by charging the battery pack or placing the battery pack into the e-bike.

**Deep Sleep Mode**

To minimise the system’s internal consumption, the battery pack automatically switches to the **Deep Sleep Mode** after 2 hours in **Active Mode**, if there is no activity and if the display unit is switched off. The **Deep Sleep Mode** is also activated if the LED button (28) or the On/off button of the display unit is pressed for at least three seconds or if the battery pack is not in the e-bike for more than 30 seconds.



## Maintenance, cleaning and storage

### Deep Sleep Mode

Keep the battery pack clean. Clean it carefully with a dry and soft cloth. The battery pack may not be dipped into water or cleaned with a water jet. If the battery pack no longer functions, please contact an authorised dealer. Only place the battery pack on a clean surface. In particular, avoid soiling on the charging connections and the contacts.

### Service Life

The service life of the battery pack can be extended if it is maintained and, in particular, stored in the right conditions.

Temperature	18-23°C
Air Humidity	0-80 %
Charging status	approx. 50 %

As the battery pack gets older, its capacity will decrease, even if it is well kept. If the operating time is much shorter after charging, this indicates that the battery pack is spent. It should be replaced.

### Storage

After about three months in storage, check the charging status of the battery pack and charge it up to about 50 % if necessary.

## Transport

The battery pack may only be sent in hazardous good packaging bearing the relevant warning information.

Please contact an authorised dealer, if you have any questions about transportation. You can also obtain suitable transport packaging from your dealer.

## Waste Disposal

Motor, display, battery pack, speed sensor, accessories and packaging should be disposed of in an environmentally-compatible manner. Do not dispose of your e-bike and its components in the household waste system!

### Only for EU countries:



In compliance with the European Directive 2012/19/EU electrical devices that are no longer serviceable, and in compliance with the European Directive 2006/66/EG faulty or spent battery packs/batteries, must be collected separately and disposed of in an environmentally-friendly manner.

Please hand in all spent battery packs and non-functional displays to an authorised bicycle dealer.

## Technical data

Please see the data sheet provided by the cycle manufacturer for details about the technical data of the battery pack used in your e-bike.

# Battery Charger

## Safety guidelines

### **WARNING**

**There is a risk of danger, if the safety instructions are not observed**

*Non-observance of safety information and instructions can lead to an electrical shock, fire and/or serious injuries.*

– Please observe all safety information and instructions both in these and in all other instructions included with the e-bike.

- Risk of an electrical shock if penetrated by water: the battery charger should never be exposed to excessive moisture (e.g. rain, snow etc.).
- Risk of fire and explosion if the wrong batteries are charged. Only use the battery charger supplied for the rechargeable battery in your Brose e-bike system. The rechargeable battery voltage and charging voltage of the battery charger must match.
- Risk of electrical shock caused by dirt: always keep the battery charger clean.
- There is a higher risk of an electrical shock from damaged battery chargers, cables and connectors: always check the battery charger, cable and connector before use. If you establish any damage, do not use the battery charger under any circumstances. Do not open the battery charger and only allow it to be repaired by qualified specialists and only using original spare parts.
- Risk of fire if battery charger overheats during charging: do not place the battery charger on a flammable surface (e.g. paper, textiles etc.) or operate it in a flammable environment.
- Risk of misuse and injuries: Children and persons that, because of their physical, sensory or intellectual capabilities, or because of their lack of experience or knowledge, are incapable of using the battery charger safely, must not use this equipment without the supervision or guidance of a responsible person.
- Never leave the battery pack and battery charger unattended during charging.
- Please keep these instructions for future reference.

There is a brief version of the most important safety instructions in English, French and Spanish on the underside of the battery charger with the following content:

- Observe the operating instructions to ensure safe use. Risk of an electrical shock.
- Only use in dry environments.

- Only charge battery packs of the Brose e-bike system. Other battery packs could explode and cause damage.
- Do not replace the mains cable. There is a risk of fire and explosion.

## Intended use

The battery charger may only be used to charge the battery packs supplied with the e-bike.

## Explanation of the figures

All illustrations are outlines only and serve as examples. The details may vary from your own e-bike because the Brose e-bike system can be combined with a number of different battery chargers. You can obtain detailed information about the battery charger supplied with your e-bike from your cycle manufacturer and your bicycle dealer.

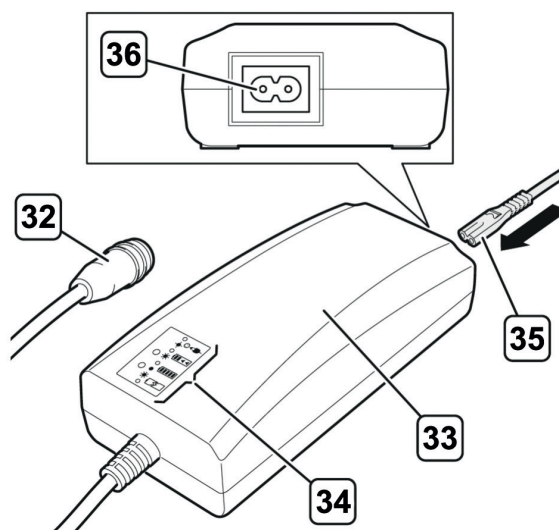

## Commissioning

### Connect the battery charger to the mains supply

*N.B.: Check mains voltage! The voltage of the power source must correspond to the details on the type plate of the battery charger.*

1. Connect the mains connection cable to the battery charger.
2. Insert the mains supply cable into the socket.
  - The LED status display of the battery charger should now be active.
  - The battery charger is now operational.

## Operation

### Charging the battery pack

Only charge the battery pack in compliance with all safety instructions.

#### For removed battery pack:

1. Switch off battery pack (see “Battery pack” on page 14).
2. Remove battery pack from the bracket on the e-bike.  
N.B.: Only place the battery pack on a clean surface. In particular, avoid soiling on the charging connections and the contacts.
3. Insert the charging connector of the battery charger into a matching charging slot on the battery pack.  
→ Charging begins.

#### Charging the battery pack on the e-bike

See “Battery pack” on page 14.

1. Switch off battery pack.
2. Insert the battery charger connector into the free charging slot.  
→ Charging begins.

*N.B.: In particular, avoid soiling on the charging connections and the contacts.*

### Charging Process

Charging begins automatically as soon as the battery charger is connected to the battery pack and the mains supply.

The battery pack can be charged with and without the display unit. Without a display unit, the battery charger can only be monitored on the charging status display. The display unit can be removed during the charging process or can even be positioned after the start of the charging process. The charging status is shown with the charging status display on the battery pack and via the bar on the display unit. During the charging process, the LEDs of the charging status display on the battery pack shine (see “Battery pack” on page 14).

*N.B.: Be careful, if you touch the battery charger during charging. It may become very hot, especially when ambient temperatures are high.*

Once the battery pack is completely charged, the LEDs will go out. The charging process is completed.

1. Disconnect the battery charger from the mains supply.
2. Disconnect the battery pack from the charger.  
→ Then the battery pack switches itself off.

If, after charging, the battery pack is not removed from the battery charger and the battery charger is still connected to the mains supply, it will switch on again after a few hours, check the charging status of the battery pack and may start charging again if necessary.

### LED status displays

2-A battery charger	
Standby	green LED shines
Precharging	green and red LED flash
Charging process	red LED shines
Battery pack full / trickle charging	green LED shines
Rechargeable battery test	green LED shines

4-A battery charger	
Standby	green LED flashes
Charging process	red LED shines
Battery pack full / trickle charging	green LED shines
Error	green and red LED flash

## Maintenance and cleaning

If the battery charger fails, please contact an authorised dealer.

Use a soft dry cloth to clean the battery charger. Do not use water or other cleaning fluids!

## Waste Disposal

The battery charger, accessories and packaging should be disposed of in an environmentally-compatible manner. Do not dispose of the battery charger in the household waste system

#### For EU countries only:



In compliance with the European Directive 2012/19/EU electrical devices that are no longer serviceable, and in compliance with the European Directive 2006/66/EG faulty or spent battery packs/batteries, must be collected separately and disposed of in an environmentally-friendly manner.

## Technical data

<b>2-A battery charger</b>	
Dimensions (mm)	140 x 70 x 40
Weight	475 g
Final charging voltage	42 V DC
Rated output current	2 A
Temperature range operation	-10 ... 40°C
Temperature range storage	-20 ... 70°C

<b>4-A battery charger</b>	
Dimensions (mm)	206,0 x 94,0 x 59,0
Weight	770 g
Final charging voltage	42 V DC
Rated output current	4 A
Temperature range operation	0 ... 45°C
Temperature range storage	-20 ... 70°C

# Troubleshooting

If any problems occur during use of your Brose e-bike system, first of all check them off against those listed in the table. This will enable you to solve the problem yourself in many cases.

Symptom	Possible cause	Solution approach
Display unit (1) and/or Brose e-bike system cannot be activated.	Malfunction of battery pack (26) despite full charge.	Press the LED button (28) to check whether the battery pack can be switched on. The LEDs of the charge level display (27) on the battery pack (26) should come on. If this is not the case, there may be a defect in the battery pack (26).
	Battery pack (26) not correctly snapped into mounting (31).	Remove the battery pack (26) again and then re-insert it. Ensure that it is seated correctly.
	Battery pack (26) not charged.	Complete a charging operation using the supplied battery charger (33).
	Contacts of battery pack (26) and/or of mounting (31) fouled.	Check that all contacts are clean. If necessary clean them with a soft and dry cloth.
	Display unit (1) not correctly snapped into mounting (2).	Remove the display unit (1) again and then re-insert it. Ensure that it is seated correctly.
	Contacts of display unit (1) and/or of mounting (2) fouled.	Check that all contacts are clean. If necessary clean them with a soft and dry cloth.
	Plug connections at the drive unit not correctly inserted.	Check the cables and plug connections, and connect them properly where necessary.
Display unit (1) not supplying cycling data even though the e-bike is in motion.	Spoke magnet (23) not correctly fitted (distance from speed sensor (25)).	Check the fitting of the spoke magnet (23), particularly its distance from the speed sensor (25) on the chain stay. This distance must be between 5 and 17 mm (see Fig. 8). Correct the distance where necessary.
Bike lights cannot be activated.	Cable for lights incorrectly connected.	Check the cables and plug connections, and connect them properly where necessary.
Display unit (1) displays an error code in the multifunctional panel (15).	There is an active error in the system.	Please refer to the following table.

## Error codes

You can see from the following table which error is present in the system and what can be done when your display unit (1) displays an error code.

Error code	Description	Solution approach
10	The battery voltage is too low	Charge the battery pack (26) using the battery charger (33).
11	The battery voltage is too high	Switch off the system completely and then back on using the LED button (28) on the battery pack (26). If the problem persists, contact your e-bike dealer.
12	The battery is almost/completely discharged	Charge the battery pack (26) using the battery charger (33).
20	Electrical measurements are faulty	Switch off the system completely and then back on using the LED button (28) on the battery pack (26). If the problem persists, contact your e-bike dealer.
21	Thermo sensor defective	
23		
24	The internal voltage is outside the working range	Charge the battery pack (26) using the battery charger (33).
25	Error in motor current measurement	Switch off the system completely and then back on using the LED button (28) on the battery pack (26). If the problem persists, contact your e-bike dealer.
26	A software reset has been performed	
30	Error in push-assist	
40	Over-current detected in motor	Reduce the load on the motor by pedaling less or by reducing the assist level.
41	Over-current detected in motor	Reduce the load on the motor by pedaling less.

<b>Error code</b>	<b>Description</b>	<b>Solution approach</b>
42	Fault in motor turning	Switch off the system completely and then back on using the LED button (28) on the battery pack (26). If the problem persists, contact your e-bike dealer.
43	Short-circuit in motor	
44	Overheating of motor	Reduce the load on the motor by pedaling less or by reducing the assist level.
45	The software has corrected an error during turning of the motor	Switch off the system completely and then back on using the LED button (28) on the battery pack (26). If the problem persists, contact your e-bike dealer.
46	No motor movement detected although a current of > 2 A was measured	
60	Interruption of data exchange on the CAN BUS	Check the cables and plug connections of all components of the e-bike system.
70	Force applied to pedal not in valid range	Switch off the system completely and then back on using the LED button (28) on the battery pack (26). If the problem persists, contact your e-bike dealer.
71	Turning of pedals not detected	
72	Force applied to pedal not detected	
73	Fault in link to pedal force sensor	
80	Incorrect motor parameter	Switch off the system completely and then back on using the LED button (28) on the battery pack (26). If the problem persists, contact your e-bike dealer.
81	Speed signal is not recognized	Ensure that the spoke magnet is correctly positioned relative to the speed sensor (Fig. 8).
82	The program has been manipulated	Switch off the system completely and then back on using the LED button (28) on the battery pack (26). If the problem persists, contact your e-bike dealer.
83	Error in program sequence	
84	Incorrect motor parameter	

Your notes

Brose Antriebstechnik GmbH & Co.  
Kommanditgesellschaft, Berlin  
Sickingenstraße 29-38  
10553 Berlin  
Germany

Phone: +49 30 343498 100  
Fax: +49 30 343498 122  
[ebike.berlin@brose.com](mailto:ebike.berlin@brose.com)  
[brose-ebike.com](http://brose-ebike.com)  
[facebook.com/broseebike](https://facebook.com/broseebike)