



TRIOBIKE



BOXTER

SEAT ASSEMBLY INSTRUCTIONS

ENGLISH V 1.1



## 2 KIDS SEAT KIT PARTS

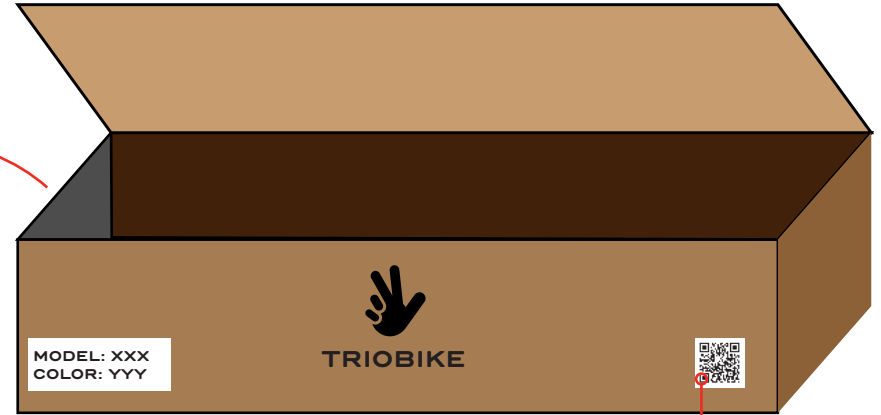

QR code - scan to download the manual

Backrest

Seat (with Velcro on the back side)

3x L shaped brackets:

- 1x to mount upside

- 2x to mount downside

4x DIN 912 M4x8 bolts with integrated washer

2x 3-points seat belts

4x DIN 912 M5x12 bolts

2x DIN 912 M6x14 bolts

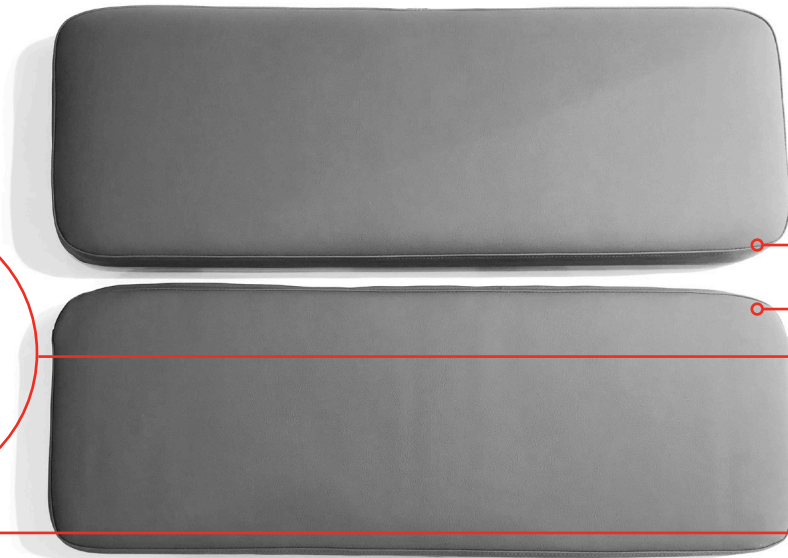



## NEEDED TOOLS

---



1- Hex key, sizes: 3, 4, 5 mm



2- Wrench, sizes: 10 mm





## ASSEMBLING THE SEAT

ALL PICTURES SHOW 4 KIDS CONFIGURATION

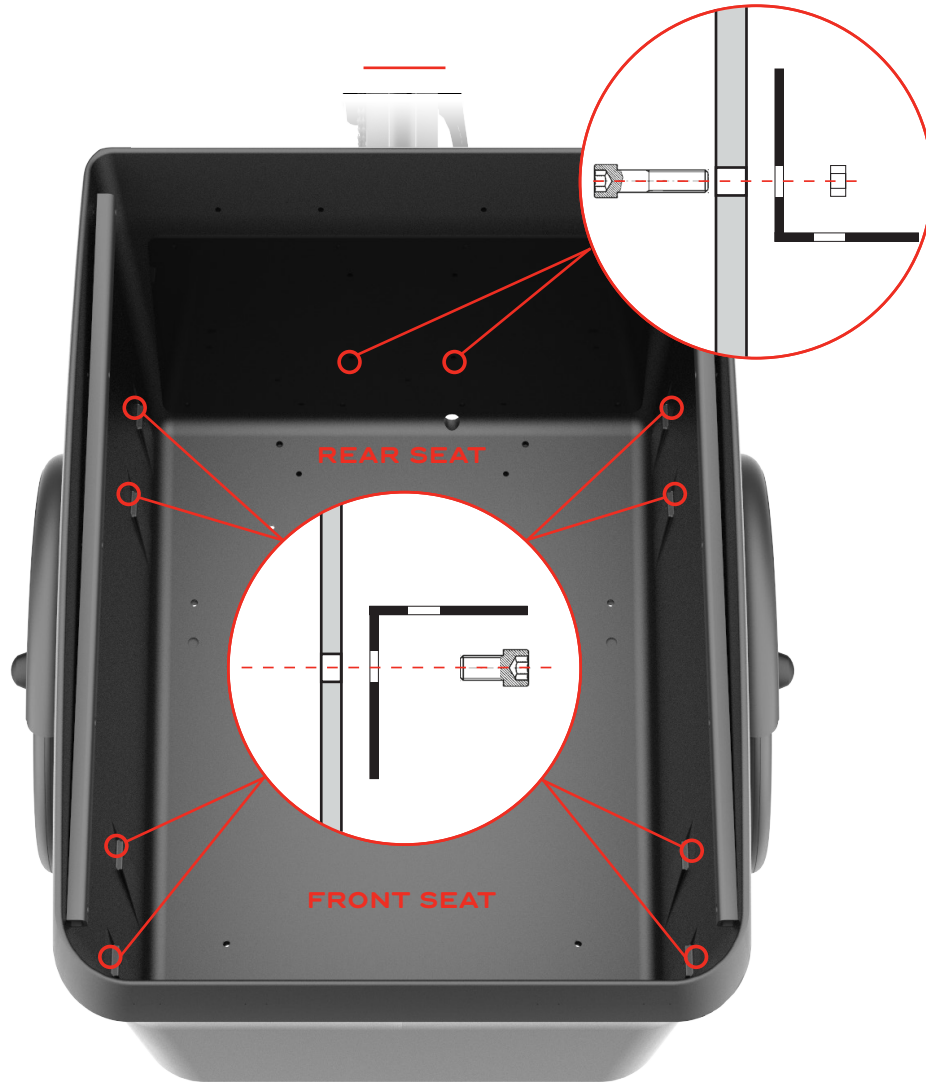

**1-** Mount the brackets on the box, using 2xM4 bolt for each bracket, in the positions shown above. **ONLY FOR REAR SEAT:** mount a bracket in the middle of the box rear wall, upside down compared to the other brackets (use the bolts and nuts from the steering column). **USE A TORQUE OF 5 Nm MAX.**

6

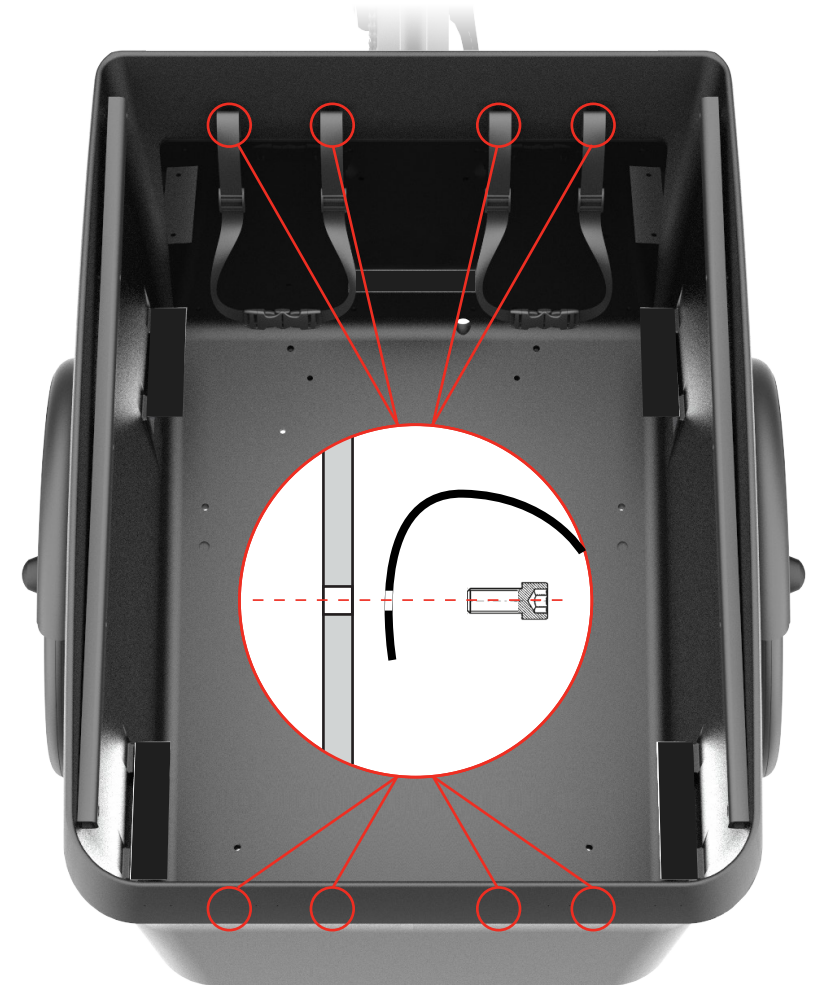

**2-** Connect seat belt shoulder holders to the rear wall on the box with 2xM5 bolt each in the specific threaded holes. **USE A TORQUE OF 5 Nm MAX.**

7

## ASSEMBLING THE SEAT

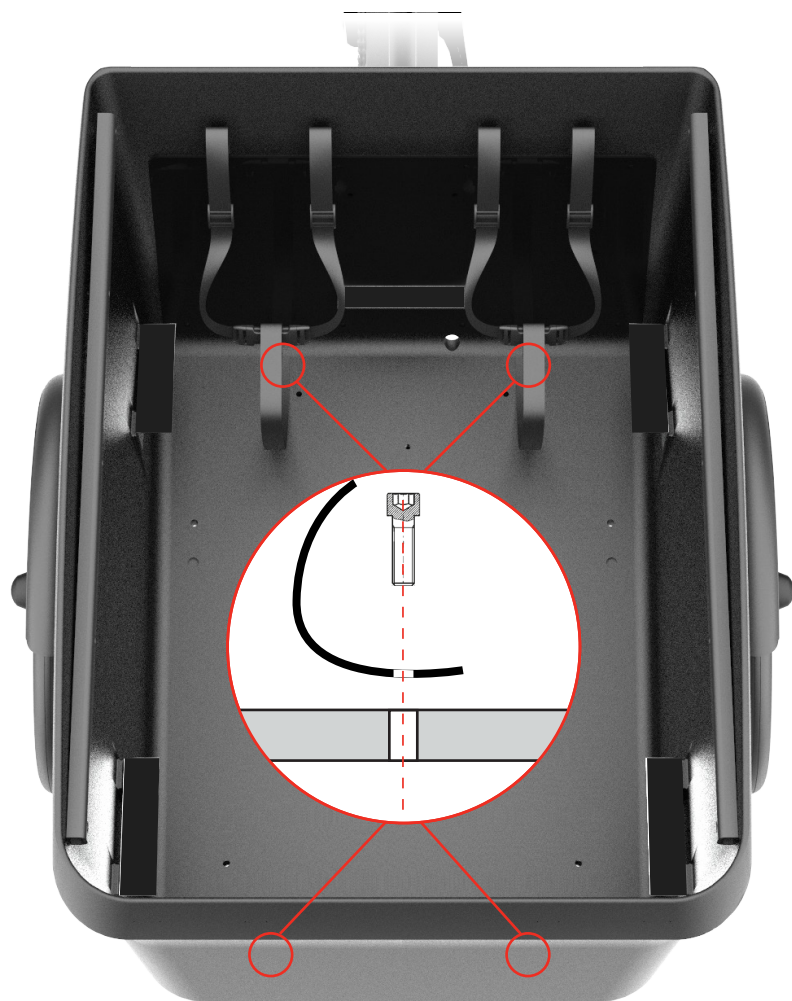

**3-** Connect seat belt bottom parts to the box floor, using 1xM6 bolt each in the specific threaded holes.

**8**

## ASSEMBLING THE SEAT



**4-** Remove the protectors from the Velcro strips on the backrest rear side.

**5-** Place the backrest on the box, as shown on picture. Apply some force so that the Velcro adheres.

**9**

## ASSEMBLING THE SEAT



**6-** Place the seat on the brackets, aligned with the Velcro, and push so that the Velcro adheres.



TRIOBIKE

TRIOBIKE A/S

Vesterbrogade 149, 1620 Copenhagen V - Denmark

phone: +45 3670 0070

[info@triobike.dk](mailto:info@triobike.dk) | [www.triobike.com](http://www.triobike.com)